

MCU Kit

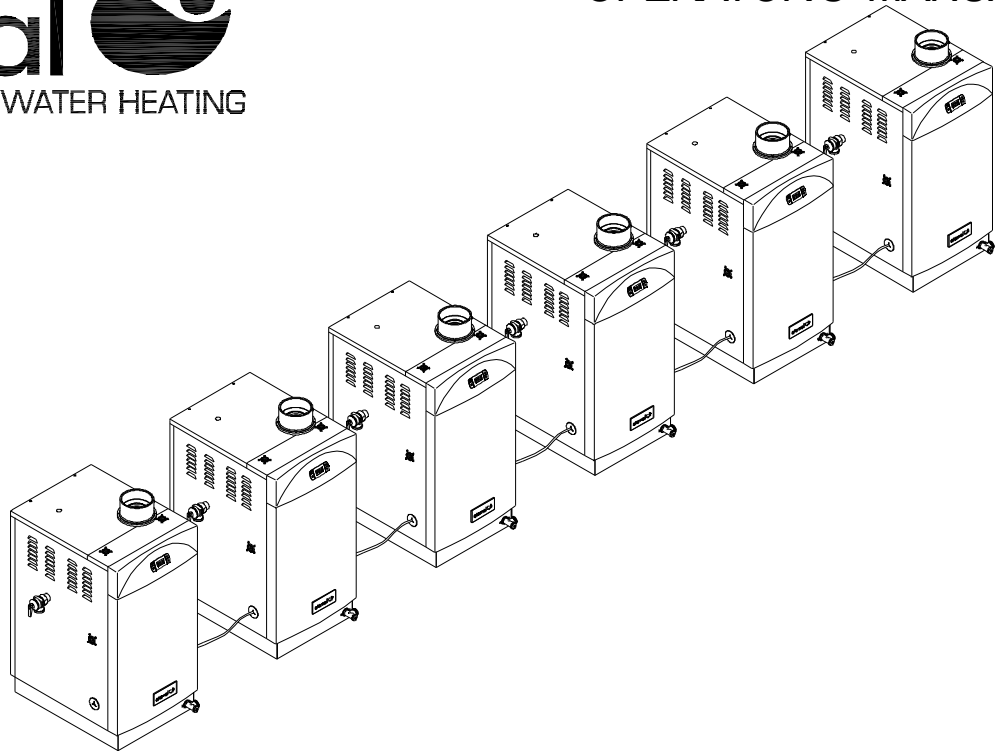

Service Information Center:

Call us first if you have any questions with this product. We can help you with questions about assembly and Water Heater operation or if there are damaged or missing parts when you unpack this unit from the shipping box. Please call before returning to the store.

1-866-946-1096
 8am-4:30pm CST, Monday through
 Friday

Table of Contents

| | |
|---|-------|
| MCU Kit Components..... | 2 |
| Specifications and Features..... | 3 |
| MCU Installation in Eternal Water Heater..... | 4-6 |
| Unique Unit Identification Number..... | 7 |
| Termination Setting..... | 8 |
| MCU Operation Sequence Flow Chart..... | 8 |
| Power Supply Schematic Diagram..... | 9 |
| Water Pipe Sizing..... | 10 |
| Gas Pipe Specification..... | 11 |
| Unit Clearance..... | 11 |
| Plumbing Diagrams..... | 12-14 |
| Warranty..... | 15 |

IMPORTANT:

- **Only specially trained and authorized personnel are permitted to service this water heater.**
- **NOTE TO ASSEMBLER / INSTALLER:**
 Leave this manual with the consumer.
- **NOTE TO CONSUMER:**
 Keep this manual for future reference.



WARNING



California Proposition 65 lists chemical substances known to the state to cause cancer, birth defects, death, serious illness or other reproductive harm. This product may contain such substances, be their origin from fuel combustion (gas, oil) or components of the product itself.



WARNING



Read this Operator's Manual carefully and be sure your Water Heater is properly assembled, installed and maintained. Failure to follow these instructions exactly could result in a fire or explosion, serious bodily injury and/or property damage.

Do not store or use gasoline or other flammable vapors and liquids in the vicinity of this or any other appliance.

MCU Kit Components

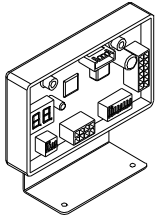

MCU Module with Bracket

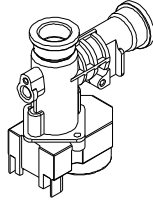

Staging Valve

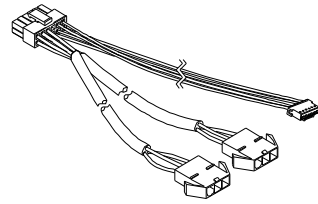

12P MCU Wire

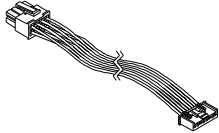

8P MCU Wire

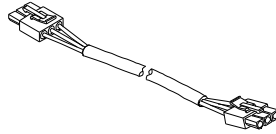

3P MCU Wire

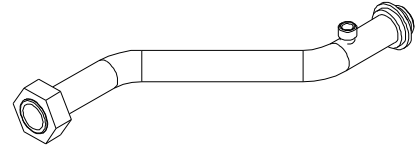

Hot Water Tube M1

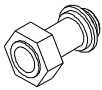

Hot Water Tube M2



WPS Nipple



WS Nipple

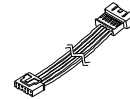

MCU Wire 5P (For DV Model)

Hardware



Cable Clamp-2pc



Tube Packing 1/2P-1pc



Tube Packing 3/4P-2pc



O Ring P4-1pc

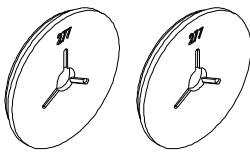

Hole Plug-2pc



Philips Head Screw-2pc



Self Tapping Screw-2pc

Specifications and Features

Applicable Models:

501 Series - GU20 / 26 / 28 / 32

505 Series - GU20DV / 26DV / 28DV / 32DV

Affected Serial #s:

GU32 prior to G800839 requires PCB upgrade for MCU compatibility

GU26 prior to G801085 requires PCB upgrade for MCU compatibility

Description:

MCU kit allows multiple Eternals to be linked {required on 3 or more units, 1 kit per unit} together in parallel manifold configuration. By doing so, Eternals can be suitable for large commercial projects. such as motels, apartment complexes and laundromats etc...

Specifications

| | |
|-------------------------|----------------------------|
| Dimensions (MCU module) | 3.94"W x 0.78 "D x 1.77 "H |
| Weight (MCU module) | Less Than 1 lb |

Features and Benefits

- High Tech CANBUS Protocol ensures good communication between units.
- Alternate Host Firing distributes wear and tear across all units every 24 hours.
- Redundency program allows remaining units to work when a units breaks down.
- Synchronized temperature control changes settings on all units from any unit.
- Up to 16 Eternals can be networked and mixed and matched, i.e. 2 x GU26s + 3 x GU32s.
- Automated staged firing allows as little or as much units to fire up as needed.
- Automated load balancing distributes the work across necessary units evenly.
- Built-in digital monitor on MCU module for easy diagnostics.
- UL1998 Certified.

MCU Installation in Eternal Water Heater

1. With all taps closed and unit off, unplug the power cord of the unit from the power outlet.
2. Using a small wrench, loosen the nut holding the outlet thermistor in hot water outlet tube and extract the outlet thermistor from the tube. Be careful not to lose the O-Ring on the thermistor.
3. Unplug the two wires attached to the Water Pressure Sensor and hand loosen the sensor to remove from the hot water outlet tube.
4. Loosen the brass nut attaching the hot water outlet tube to the water fitting near the top of the unit, and loosen the brass nut attaching the hot water outlet tube to the T-Connector near the heat exchanger tank.
5. Remove the factory original hot water outlet tube and replace with the hot water staging valve assembly (Hot Water Tube M1 + Staging Valve + Hot Water Tube M2). Secure the assembly to the water fitting and the T-Connector with brass nuts.

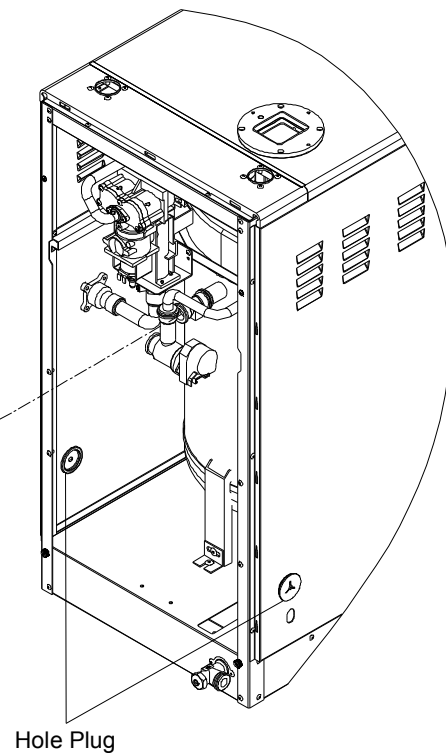
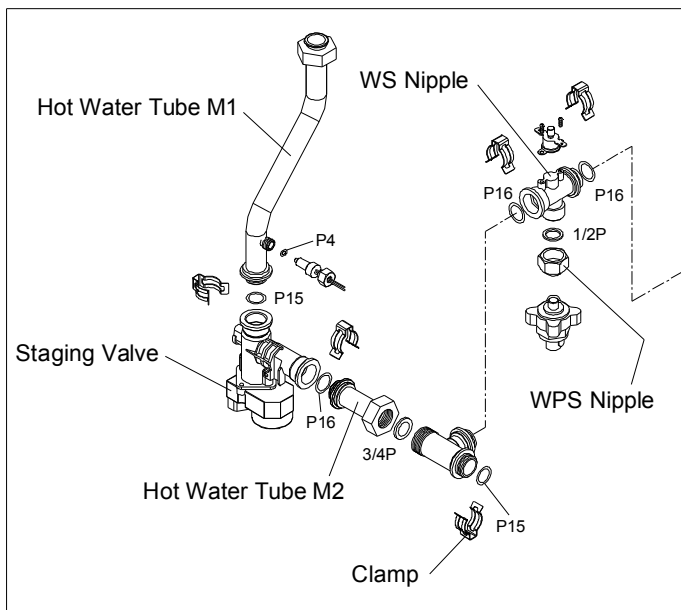
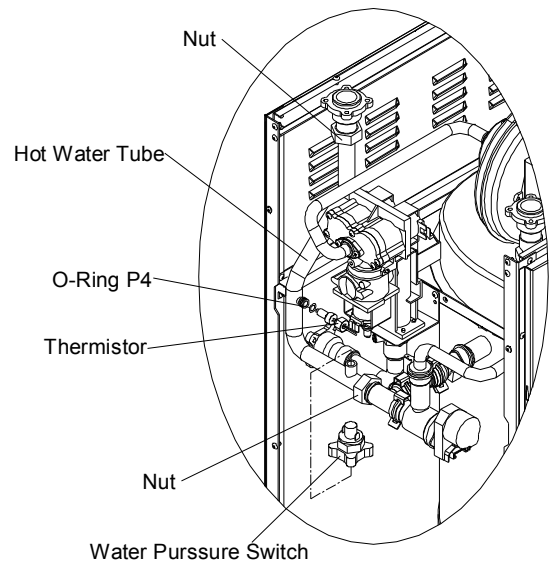

6. Insert outlet thermistor into Hot Water Tube M1 and make sure the O-Ring is secure to prevent leak.
7. Re-install the Water Pressure Switch onto the WPS Nipple. Attach the WPS Nipple and O-Ring to the WS Nipple and ensure all connections are secure to prevent leak.
8. Push open the hole(s) reserved on either or both sides and insert the Hole Plug to allow wire access.

MCU Installation in Eternal Water Heater

9. Install MCU module on the bottom panel of water heater with the included self tapping screws-2pc.

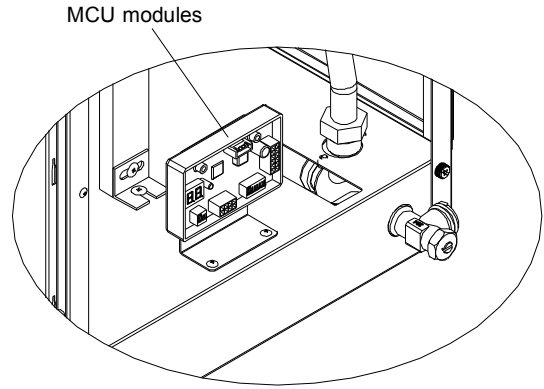

10. Connect the 8P MCU wire connector to the MCU Module.

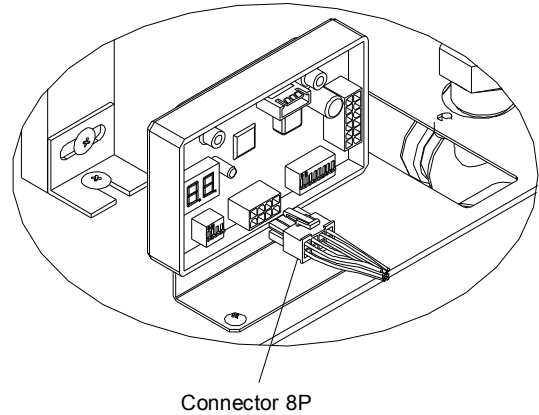

11. Connect the other end of the 8P MCU wire connector to the staging valve.

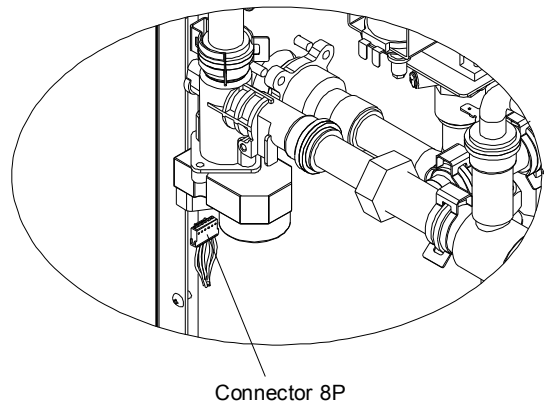

12. Connect the 12P MCU wire connector to the MCU Module.

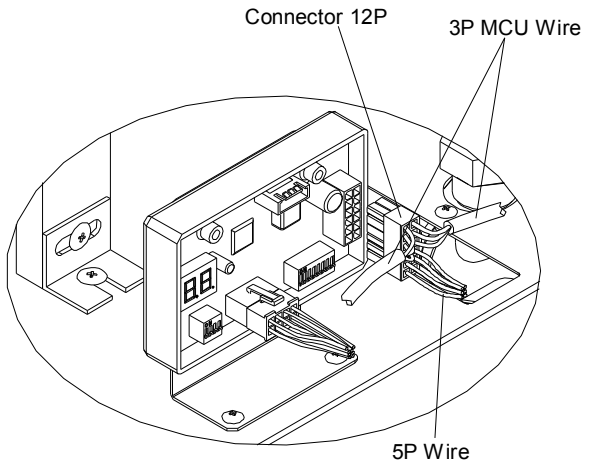

MCU Installation in Eternal Water Heater

13. Connect the 3P MCU wire connector which extends from the 12P MCU wire connector to the other 3P MCU wire connector extending from another Eternal unit next in line.

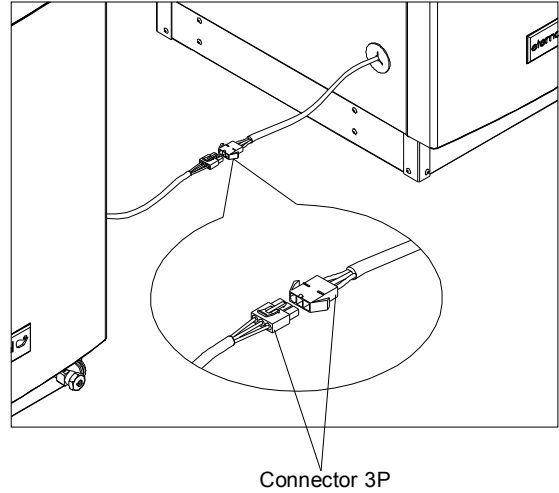

14. Connect 5P wire connector to Main Controller of the water heater.

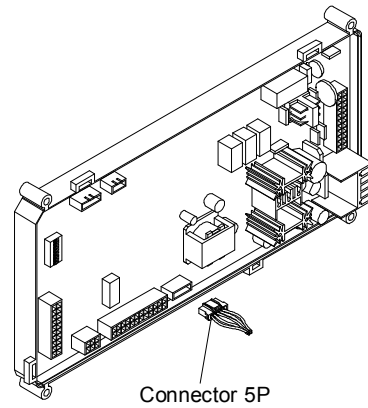

15. Secure the 3P MCU wire connectors to the bracket via the included cable clamps-2pc.

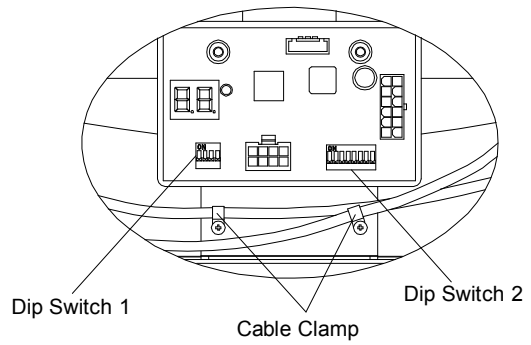

16. Repeat the installation procedure for remaining Eternal water heaters to be used in the MCU application.
17. Make sure all the units are properly configured (Unit ID# and Network Termination).
18. Move dip switch #4 to ON position on the Main Controllers of the units installed with MCU modules.

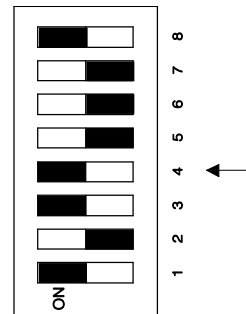

Unique Unit Identification Number

All units networked need to be assigned unique ID numbers. For example, if 3 units are used, the first unit should be assigned #1 by pushing Dipswitches 1,2,3 and 4 to OFF position. The second unit should be assigned #2 by pushing Dipswitch 1 to ON position while leaving the rest in OFF position. The third unit should be assigned #3 by pushing Dipswitch #2 to ON position while leaving the rest in OFF position.

If two units are assigned the same ID# the network will not recognize the units correctly.

| How many units installed | Identification |
|--------------------------|---|
| 2 units | #1, #2 |
| 3 units | #1, #2, #3 |
| 4 units | #1, #2, #3, #4 |
| 5 units | #1, #2, #3, #4, #5 |
| 6 units | #1, #2, #3, #4, #5, #6 |
| 7 units | #1, #2, #3, #4, #5, #6, #7 |
| 8 units | #1, #2, #3, #4, #5, #6, #7, #8 |
| 9 units | #1, #2, #3, #4, #5, #6, #7, #8, #9 |
| 10 units | #1, #2, #3, #4, #5, #6, #7, #8, #9, #10 |
| 11 units | #1, #2, #3, #4, #5, #6, #7, #8, #9, #10, #11 |
| 12 units | #1, #2, #3, #4, #5, #6, #7, #8, #9, #10, #11, #12 |
| 13 units | #1, #2, #3, #4, #5, #6, #7, #8, #9, #10, #11, #12, #13 |
| 14 units | #1, #2, #3, #4, #5, #6, #7, #8, #9, #10, #11, #12, #13, #14 |
| 15 units | #1, #2, #3, #4, #5, #6, #7, #8, #9, #10, #11, #12, #13, #14, #15 |
| 16 units | #1, #2, #3, #4, #5, #6, #7, #8, #9, #10, #11, #12, #13, #14, #15, #16 |

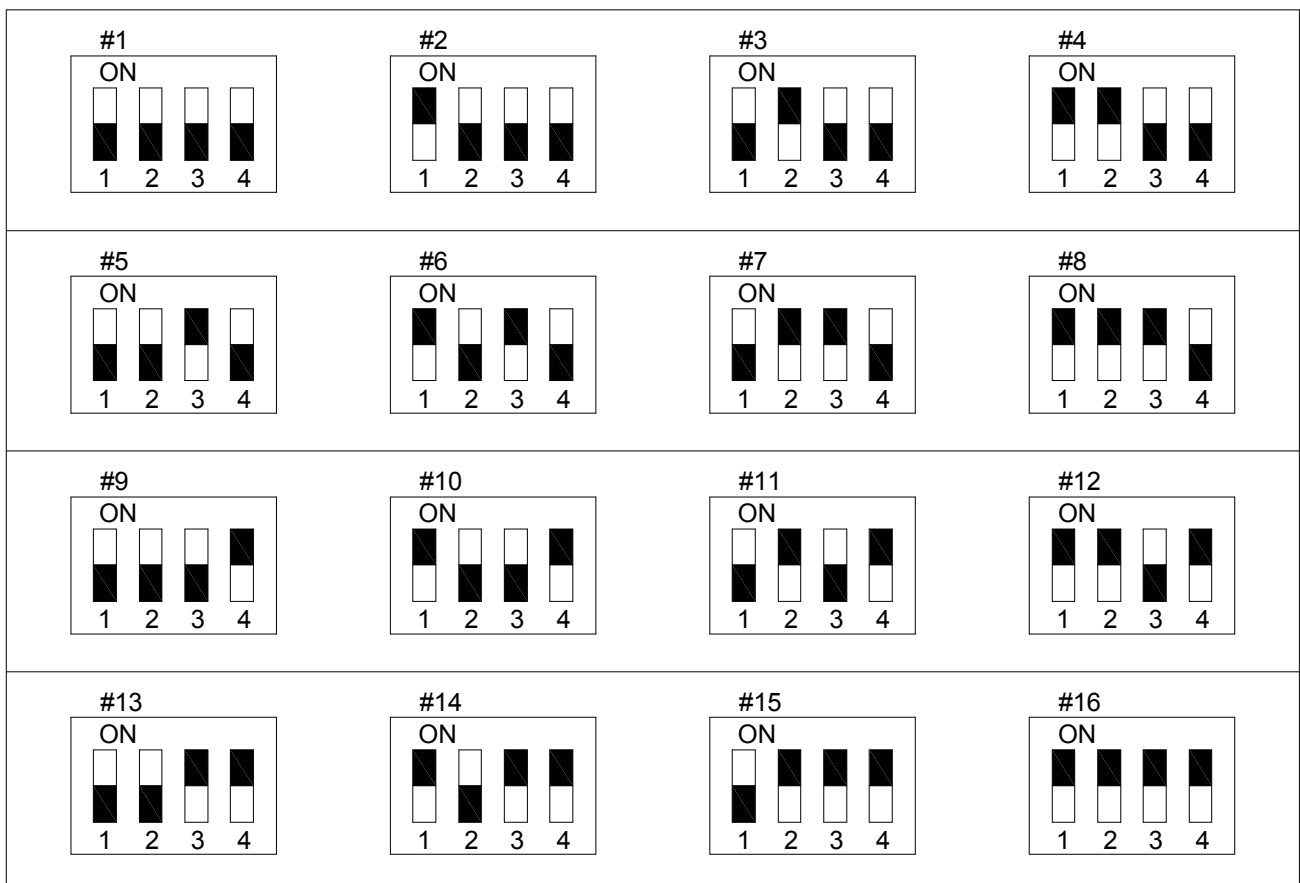

Termination Setting

MCU utilizes CAN-Bus protocol which requires physical end units to be assigned “termination” status. For example, in a 2 unit application, unit ID1 and ID2 would both need to be electronically terminated since they are both on physical ends of the network. Another example using a 5 unit application, unit ID1 and ID5 would need to be electronically terminated.

To electronically terminate the end units in a group, locate the 8-button Dipswitch on the MCU module and push Dipswitch #8 to ON position.

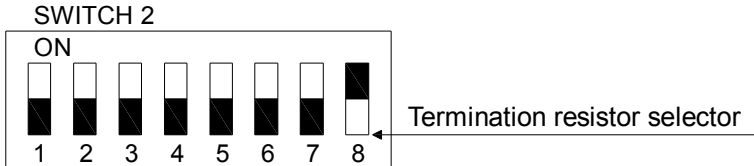

MCU Operational Sequence Flow Chart

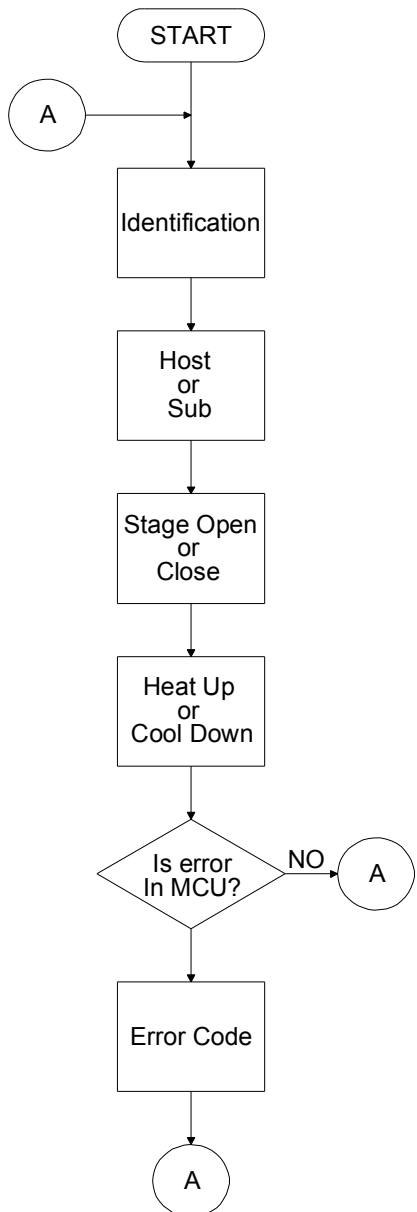

Identification - You can see the assigned unit ID# on the MCU module during this sequence.

Host or Sub - "Ho" or "Su" : This sequence displays the current Host unit in the group. The host unit is the first unit to fire when demand for hot water is detected. MCU will automatically reassign the role of Host to other Sub units every 24 hours.

Staging Valve Open or Close - This sequence will display whether the Staging Valve is open or closed.

Heat Up or Cool Down - Not all units in MCU configuration will keep hot water stored. This sequence will display which units are holding hot water reserve.

Error Codes:

- E1: Staging Valve is disconnected / Remedy: Check wiring between MCU and Staging Valve.
- E2: Staging Valve initialization error / Remedy: Replace Staging Valve.
- E3: No Sub units detected by Host / Remedy: Reset all units and make sure all units are properly configured and wired.
- E4: CAN-Bus communication error / Remedy: Reset all units and make sure all units are properly configured and wired.

Power Supply Schematic Diagram

Operating as a single unit, Eternal consumes less than 1A current, and the power supplied to the unit can be on as low as 2A capacity. However, when multiple Eternals are used together, power supply requirement is significantly increased.

Proper power supply design is important to ensure the safe operation of Eternal. When multiple units are used, the electrical supply needs to increase in capacity. Calculate by the below formula:

of units installed X 2A per unit = Total Amperage

For example, for 16 units, 32A circuit is needed to supply power to the water heaters.

We recommend AWG #8 wiring for main power supply and AWG #16 at the sockets with no more than 2 Eternal water heaters plugged into each socket. All units should be on the same breaker switch so that the entire group can be reset easily if needed.

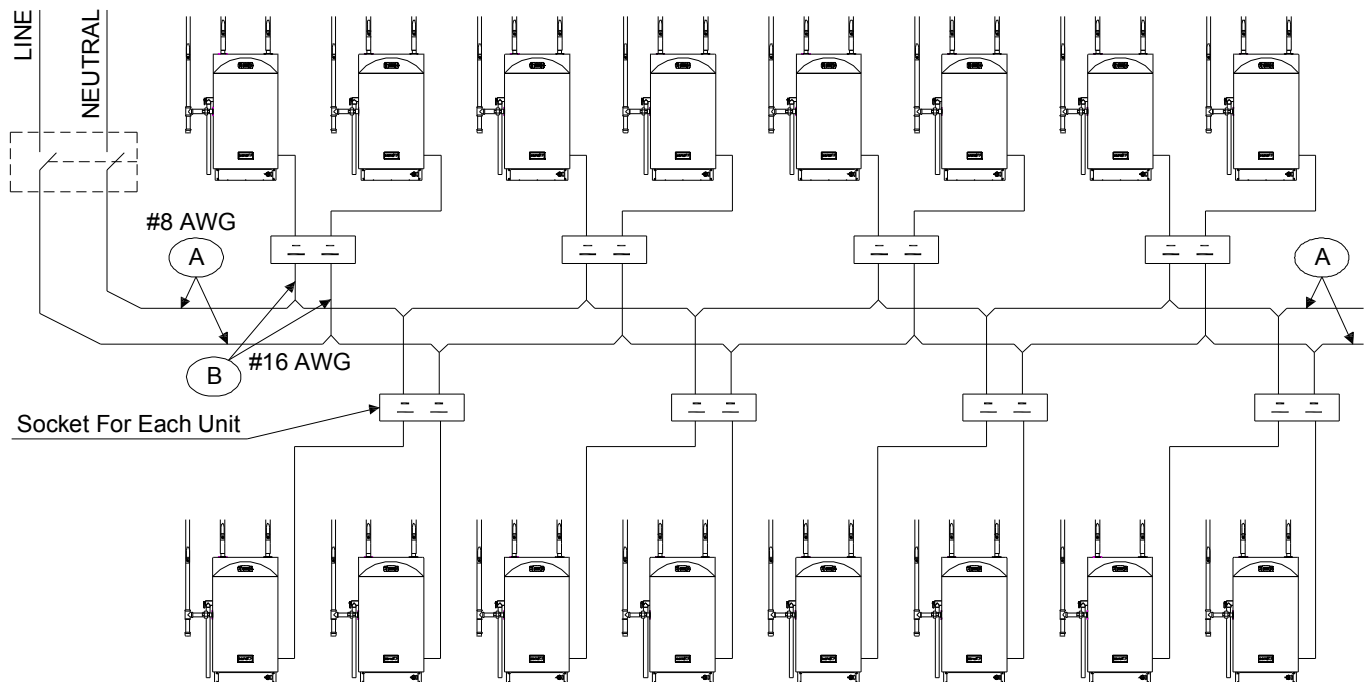

MCU Start Up / Reset Procedure

1. Locate the leakage breaker on all units.
2. Press the TEST button on the leakage breaker to suspend electric power delivery (both red and green light will be on); do this on all units.
3. After all units are suspended, let all units rest for 5 minutes.
4. Press the RESET button on the leakage breaker (only green will be on) starting from the last unit, then sequentially reset the units from last to first, i.e. reset unit 5, then 4, then 3, ect...in a 5 unit setup.
5. After all units have been reset, let rest for 5 minutes then press power button on Unit 1 to turn the entire network of units on.

Water Pipe Sizing

1. Supply pressure 30 - 39 psi

| Meter and street service pipe (inches) | Distribution pipe (inches) | GPM Capacity per Length of Pipe (ft) | | | | | | | | |
|---|-------------------------------|--------------------------------------|-----|-----|------|------|------|------|------|------|
| | | 40' | 60' | 80' | 100' | 150' | 200' | 300' | 400' | 500' |
| 3/4 | 1/2 | 2.5 | 2 | 1.5 | 1.5 | 1 | 1 | 0.5 | 0 | 0 |
| 3/4 | 3/4 | 9.5 | 7.5 | 6 | 5.5 | 4 | 3.5 | 2.5 | 2 | 1.5 |
| 3/4 | 1 | 32 | 25 | 20 | 16.5 | 11 | 9 | 6.5 | 5.5 | 4.5 |
| 1 | 1 | 32 | 32 | 27 | 21 | 13.5 | 10 | 7 | 5.5 | 5 |
| 1 | 1 1/4 | 80 | 80 | 70 | 61 | 45 | 34 | 22 | 16 | 12 |
| 1 1/2 | 1 1/4 | 80 | 80 | 80 | 75 | 54 | 40 | 25 | 17.5 | 13 |
| 1 | 1 1/2 | 87 | 87 | 87 | 87 | 84 | 73 | 56 | 45 | 36 |
| 1 1/2 | 1 1/2 | 151 | 151 | 151 | 151 | 117 | 91 | 69 | 54 | 43 |
| 2 | 1 1/2 | 151 | 151 | 151 | 151 | 128 | 99 | 72 | 56 | 45 |
| 1 1/2 | 2 | 275 | 275 | 275 | 275 | 258 | 223 | 174 | 144 | 122 |
| 2 | 2 | 365 | 365 | 365 | 365 | 318 | 266 | 201 | 160 | 134 |
| 2 | 2 1/2 | 533 | 533 | 533 | 533 | 533 | 495 | 409 | 353 | 311 |

2. Supply pressure 40 - 49 psi

| Meter and street service pipe (inches) | Distribution pipe (inches) | GPM Capacity per Length of Pipe (ft) | | | | | | | | |
|---|-------------------------------|--------------------------------------|-----|-----|------|------|------|------|------|------|
| | | 40' | 60' | 80' | 100' | 150' | 200' | 300' | 400' | 500' |
| 3/4 | 1/2 | 3 | 2.5 | 2 | 1.5 | 1.5 | 1 | 0.5 | 0.5 | 0.5 |
| 3/4 | 3/4 | 9.5 | 9.5 | 8.5 | 7.5 | 5.5 | 4.5 | 3 | 2.5 | 2 |
| 3/4 | 1 | 32 | 32 | 32 | 26 | 18 | 13.5 | 9 | 7.5 | 6 |
| 1 | 1 | 32 | 32 | 32 | 32 | 21 | 15 | 9.5 | 7.5 | 6.5 |
| 1 | 1 1/4 | 80 | 80 | 80 | 80 | 65 | 52 | 35 | 26 | 20 |
| 1 1/2 | 1 1/4 | 80 | 80 | 80 | 80 | 75 | 59 | 39 | 28 | 21 |
| 1 | 1 1/2 | 87 | 87 | 87 | 87 | 87 | 87 | 78 | 65 | 55 |
| 1 1/2 | 1 1/2 | 151 | 151 | 151 | 151 | 151 | 130 | 93 | 75 | 63 |
| 2 | 1 1/2 | 151 | 151 | 151 | 151 | 151 | 139 | 98 | 77 | 64 |
| 1 1/2 | 2 | 275 | 275 | 275 | 275 | 275 | 275 | 238 | 198 | 169 |
| 2 | 2 | 365 | 365 | 365 | 365 | 365 | 349 | 270 | 220 | 185 |
| 2 | 2 1/2 | 533 | 533 | 533 | 533 | 533 | 533 | 528 | 456 | 403 |

3. Supply pressure 50 - 59 psi

| Meter and street service pipe (inches) | Distribution pipe (inches) | GPM Capacity per Length of Pipe (ft) | | | | | | | | |
|---|-------------------------------|--------------------------------------|-----|-----|------|------|------|------|------|------|
| | | 40' | 60' | 80' | 100' | 150' | 200' | 300' | 400' | 500' |
| 3/4 | 1/2 | 3 | 3 | 2.5 | 2 | 1.5 | 1 | 1 | 0.5 | 0.5 |
| 3/4 | 3/4 | 9.5 | 9.5 | 9.5 | 8.5 | 6.5 | 5 | 4 | 3 | 2.5 |
| 3/4 | 1 | 32 | 32 | 32 | 32 | 25 | 18.5 | 12 | 9.5 | 8 |
| 1 | 1 | 32 | 32 | 32 | 32 | 30 | 22 | 13 | 10 | 8 |
| 1 | 1 1/4 | 80 | 80 | 80 | 80 | 80 | 68 | 48 | 35 | 28 |
| 1 1/2 | 1 1/4 | 80 | 80 | 80 | 80 | 80 | 75 | 53 | 39 | 29 |
| 1 | 1 1/2 | 87 | 87 | 87 | 87 | 87 | 87 | 87 | 82 | 70 |
| 1 1/2 | 1 1/2 | 151 | 151 | 151 | 151 | 151 | 151 | 120 | 94 | 79 |
| 2 | 1 1/2 | 151 | 151 | 151 | 151 | 151 | 151 | 126 | 97 | 81 |
| 1 1/2 | 2 | 275 | 275 | 275 | 275 | 275 | 275 | 275 | 247 | 213 |
| 2 | 2 | 365 | 365 | 365 | 365 | 365 | 365 | 329 | 272 | 232 |
| 2 | 2 1/2 | 533 | 533 | 533 | 533 | 533 | 533 | 533 | 533 | 486 |

4. Supply pressure over 60 psi

| Meter and street service pipe (inches) | Distribution pipe (inches) | GPM Capacity per Length of Pipe (ft) | | | | | | | | |
|---|-------------------------------|--------------------------------------|-----|-----|------|------|------|------|------|------|
| | | 40' | 60' | 80' | 100' | 150' | 200' | 300' | 400' | 500' |
| 3/4 | 1/2 | 3 | 3 | 3 | 2.5 | 2 | 1.5 | 1 | 1 | 0.5 |
| 3/4 | 3/4 | 9.5 | 9.5 | 9.5 | 9.5 | 7.5 | 6 | 4.5 | 3.5 | 3 |
| 3/4 | 1 | 32 | 32 | 32 | 32 | 32 | 24 | 15.5 | 11.5 | 9.5 |
| 1 | 1 | 32 | 32 | 32 | 32 | 32 | 28 | 17 | 12 | 9.5 |
| 1 | 1 1/4 | 80 | 80 | 80 | 80 | 80 | 80 | 60 | 46 | 36 |
| 1 1/2 | 1 1/4 | 80 | 80 | 80 | 80 | 80 | 80 | 65 | 50 | 38 |
| 1 | 1 1/2 | 87 | 87 | 87 | 87 | 87 | 87 | 87 | 87 | 84 |
| 1 1/2 | 1 1/2 | 151 | 151 | 151 | 151 | 151 | 151 | 144 | 114 | 94 |
| 2 | 1 1/2 | 151 | 151 | 151 | 151 | 151 | 151 | 151 | 118 | 97 |
| 1 1/2 | 2 | 275 | 275 | 275 | 275 | 275 | 275 | 275 | 275 | 252 |
| 2 | 2 | 365 | 368 | 368 | 368 | 368 | 368 | 368 | 318 | 273 |
| 2 | 2 1/2 | 533 | 533 | 533 | 533 | 533 | 533 | 533 | 533 | 533 |

Gas Pipe Specification

NATURAL GAS SUPPLY PIPING

| Pipe size | Cubic Feet of Natural Gas | | | | | | | | | | | |
|-----------|---------------------------|-------|-------|-------|------|------|------|------|------|------|------|------|
| | Length | 10' | 20' | 30' | 40' | 50' | 60' | 70' | 80' | 90' | 100' | 125' |
| 1/2" | 174 | 119 | 96 | 82 | 73 | 66 | 61 | 56 | 53 | 50 | 44 | |
| 3/4" | 363 | 249 | 200 | 171 | 152 | 138 | 127 | 118 | 111 | 104 | 93 | |
| 1" | 684 | 470 | 377 | 323 | 286 | 259 | 239 | 222 | 208 | 197 | 174 | |
| 1 1/4" | 1404 | 965 | 775 | 663 | 588 | 532 | 490 | 456 | 428 | 404 | 358 | |
| 1 1/2" | 2103 | 1445 | 1161 | 993 | 880 | 798 | 734 | 683 | 641 | 605 | 536 | |
| 2" | 4050 | 2784 | 2235 | 1913 | 1696 | 1536 | 1413 | 1315 | 1234 | 1165 | 1033 | |
| 2 1/2" | 6455 | 4437 | 3563 | 3049 | 2703 | 2449 | 2253 | 2096 | 1966 | 1857 | 1646 | |
| 3" | 11412 | 7843 | 6299 | 5391 | 4778 | 4329 | 3983 | 3705 | 3476 | 3284 | 2910 | |
| 3 1/2" | 16709 | 11484 | 9222 | 7893 | 6995 | 6338 | 5831 | 5425 | 5090 | 4808 | 4261 | |
| 4" | 23277 | 15998 | 12847 | 10995 | 9745 | 8830 | 8123 | 7557 | 7091 | 6698 | 5936 | |

Based on 0.60 specific gravity for natural gas at 0.5 "W.C. pressure drop DOE standard is 1100 BTU per cubic ft. of natural gas

PROPANE GAS SUPPLY PIPING

| Pipe size | KBTU of Propane Gas | | | | | | | | | | | | | |
|-----------|---------------------|------|------|------|------|------|------|------|------|------|------|------|------|------|
| | Length | 10' | 20' | 30' | 40' | 50' | 60' | 70' | 80' | 90' | 100' | 125' | 150' | 200' |
| 1/2" | 276 | 190 | 153 | 130 | 115 | 104 | 97 | 90 | 84 | 79 | 70 | 64 | 56 | |
| 3/4" | 568 | 394 | 316 | 268 | 238 | 218 | 197 | 186 | 174 | 163 | 147 | 133 | 112 | |
| 1" | 1072 | 733 | 591 | 505 | 449 | 410 | 379 | 347 | 323 | 308 | 276 | 253 | 213 | |
| 1 1/4" | 2206 | 1497 | 1213 | 1040 | 914 | 835 | 772 | 725 | 678 | 631 | 567 | 511 | 440 | |
| 1 1/2" | 3308 | 2300 | 1859 | 1560 | 1418 | 1276 | 1182 | 1087 | 1024 | 977 | 867 | 788 | 676 | |
| 2" | 6222 | 4332 | 3466 | 2993 | 2647 | 2395 | 2206 | 2048 | 1922 | 1812 | 1607 | 1496 | 1260 | |

Based on 11 "W.C. supply pressure

Unit Clearance

MCU for Eternal is designed to position the units closely together; however, the units should be spaced at least 1ft apart to allow sufficient clearance for piping and wiring. The wiring between units can be stretched no more than 3ft. Only CAN-Bus wire supplied by Grand Hall can be used to network the units and no other extension wires can be used.

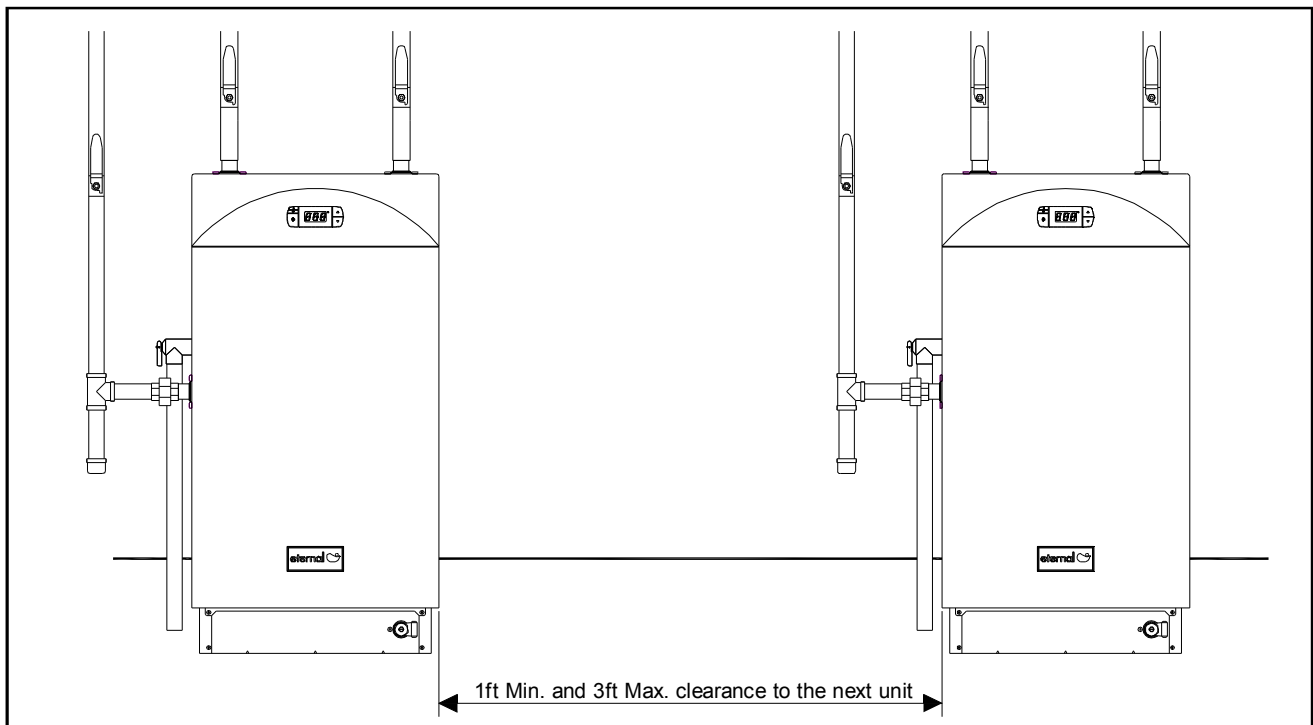

Multiple Units Used in Recirculation and Heating Applications

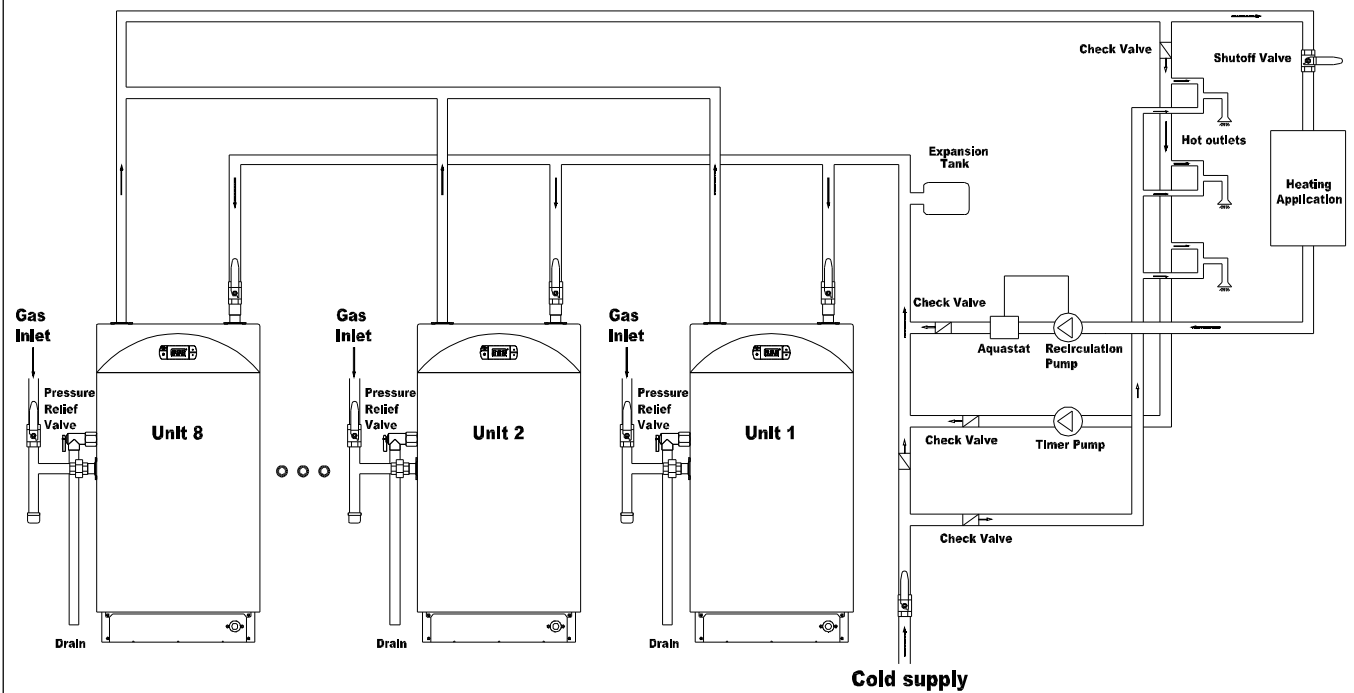

Multiple Units Used with pre-Heater, i.e. Solar

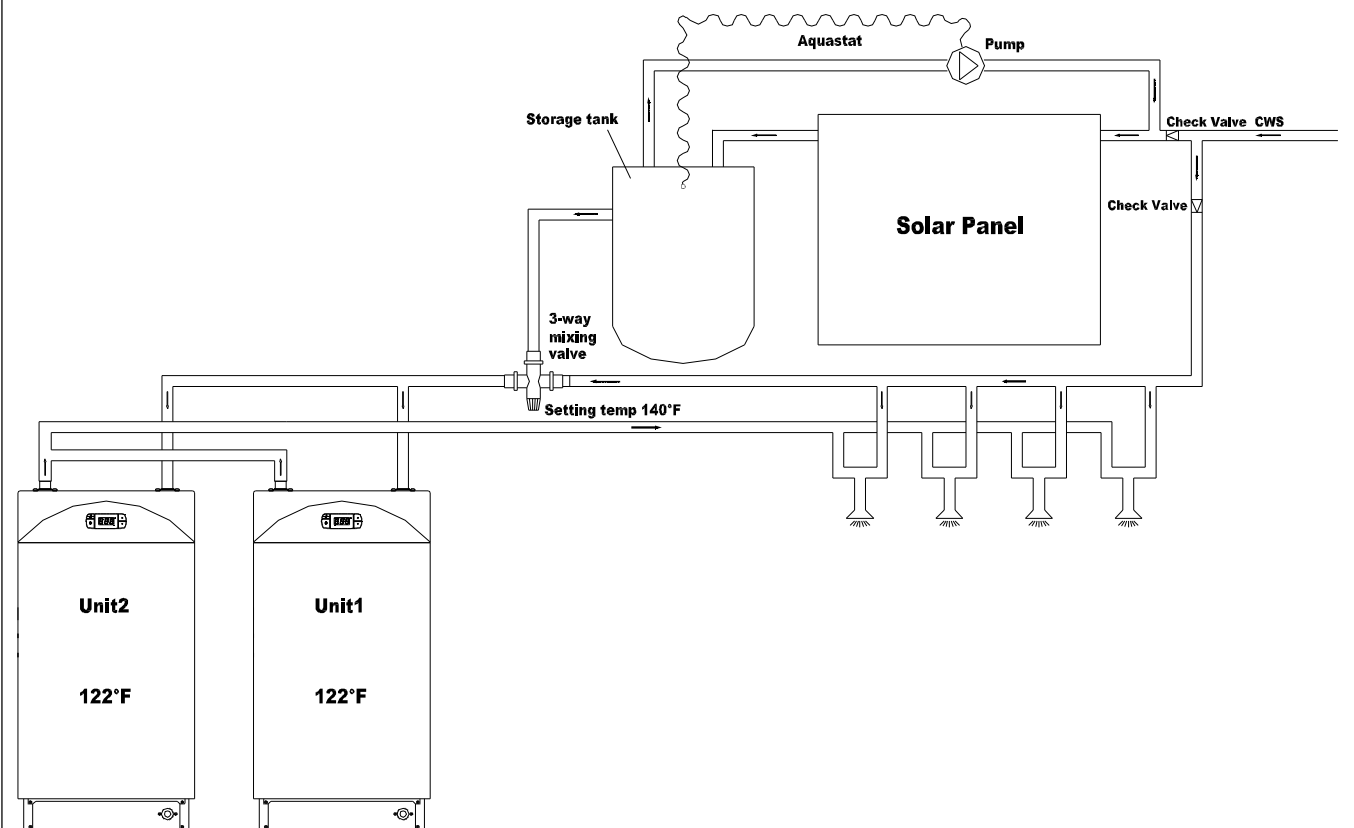

These diagrams are for reference as basic guides. Each installation should be engineered properly and compliant to Local and State Codes.

Multiple Units Used with a Storage Tank

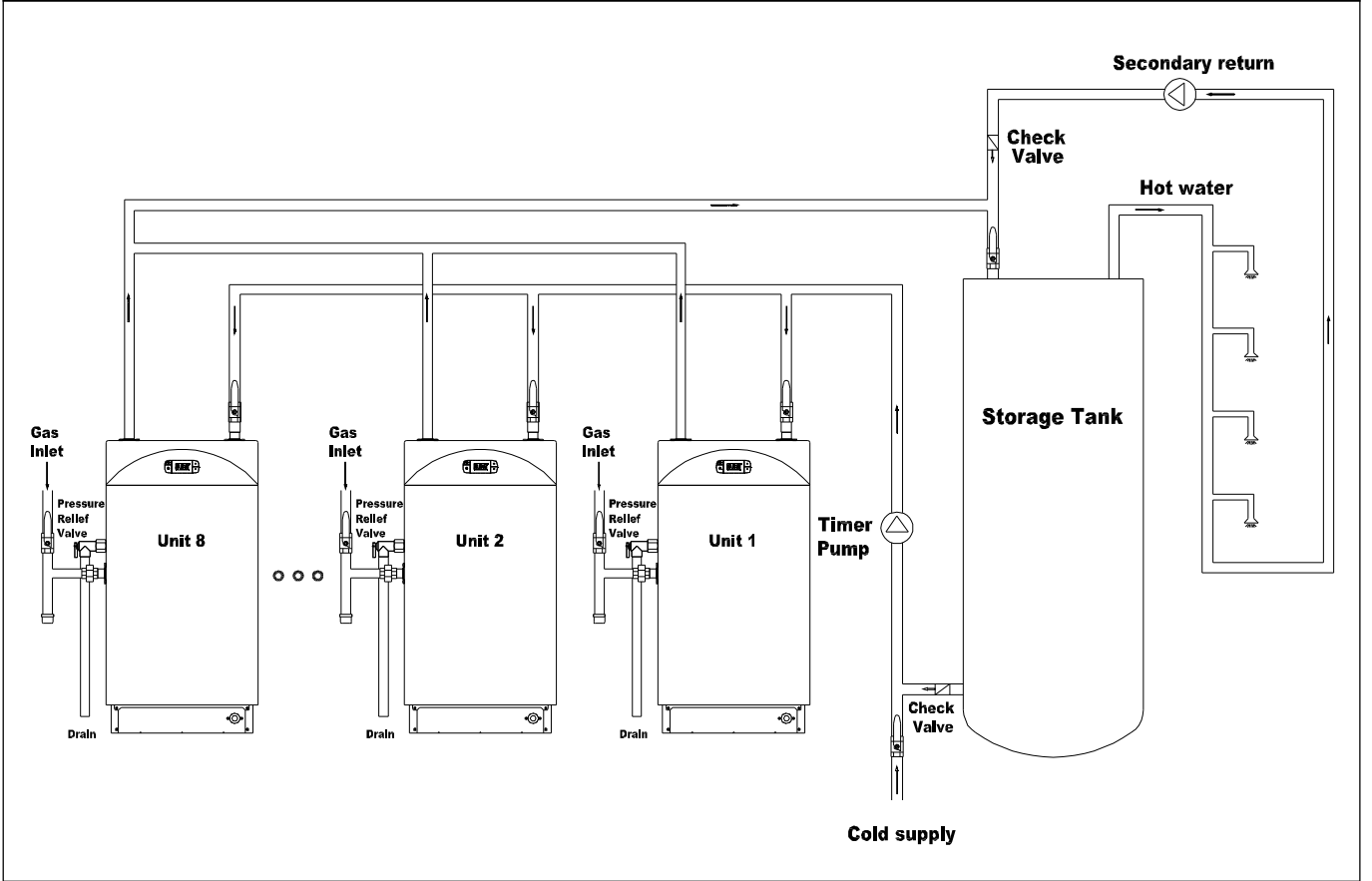

Recirculation with Multiple Units

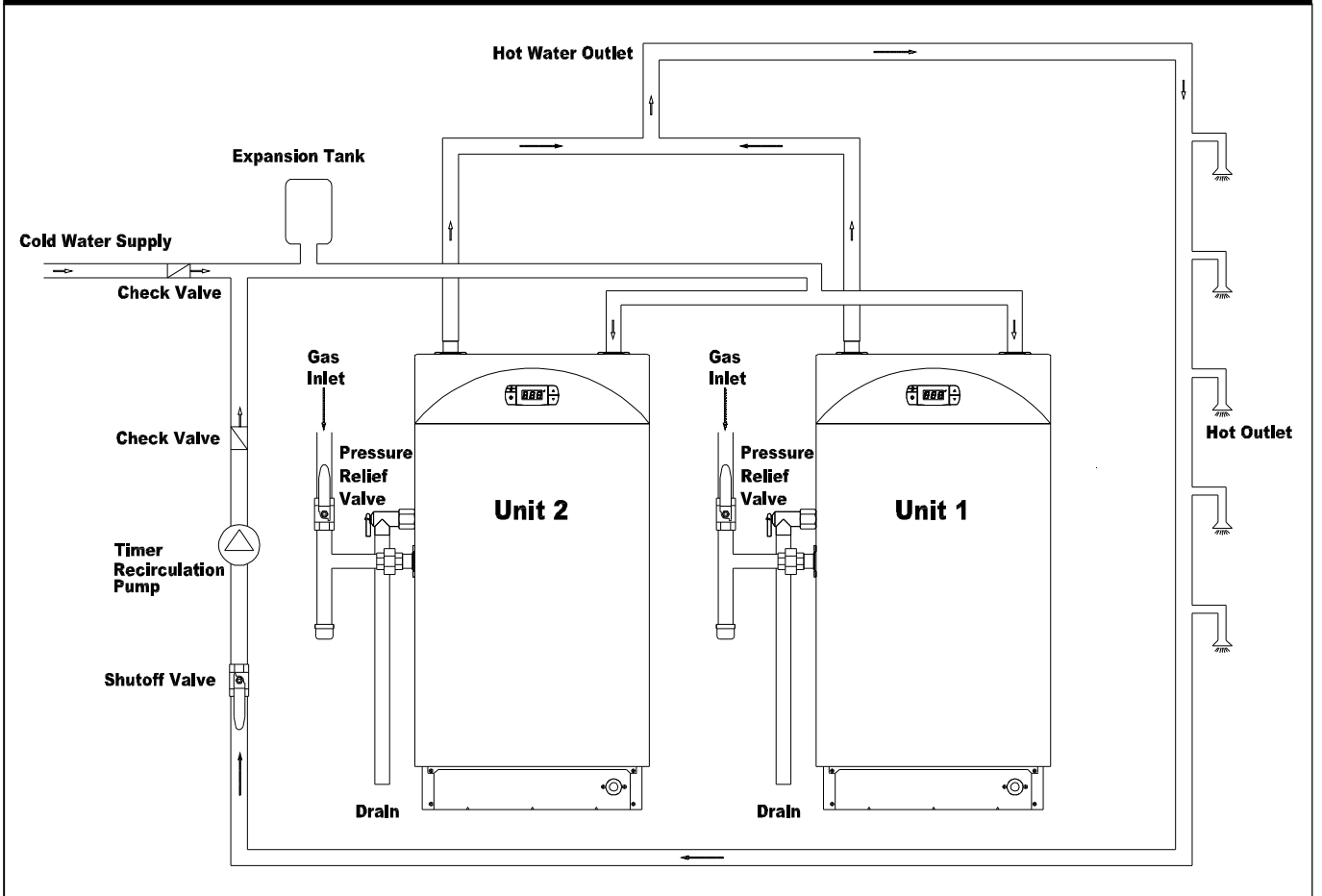

These diagrams are for reference as basic guides. Each installation should be engineered properly and compliant to Local and State Codes.

16 Units Manifold Connection

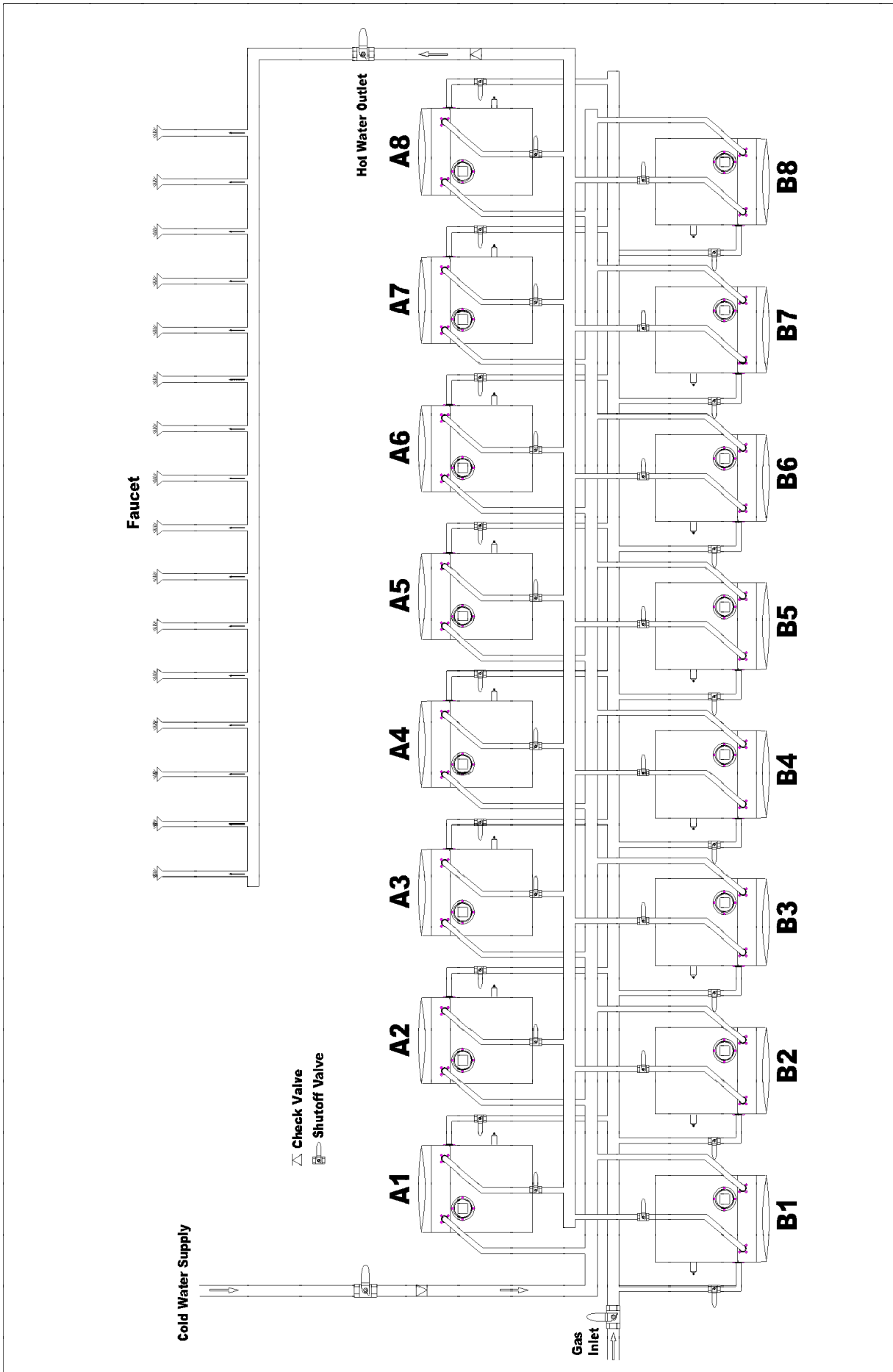

These diagrams are for reference as basic guides. Each installation should be engineered properly and compliant to Local and State Codes.

Grand Hall Limited Warranty

Grand Hall will warrant to the ORIGINAL PURCHASER of this MCU Kit that it will be free of defects in material and workmanship for set period below from the date of purchase when installed and operated in a single-family residence in accordance with the instructions in the manual and all local/state/federal codes.

MCU Kit - 3 Years Limited Warranty when initially installed together as part of Eternal Hybrid Water Heater.

Grand Hall will require reasonable proof of your date of purchase. Save your receipt in case it is required as proof of purchase.

This Limited warranty is limited to repair or replacement of parts, at Grand Hall's option that proved to be defective under normal residential use utilizing potable water.

Grand Hall may require the return of defective parts for examination before issuing replacement parts or repairs. If you are required to return defective parts, transportation charges must be prepaid.

No returns will be accepted without prior authorization from Grand Hall.

Upon examination and to Grand Hall's satisfaction, if the original part is proven defective Grand Hall may approve your claim and elect to replace such parts without charge. You are responsible for shipping charges of such replacement parts.

This Warranty does not cover any failures or operating difficulties due to accident, abuse, misuse, alteration, misapplication, vandalism, improper installation, maintenance or service, as set out in this Operator's Manual.

Deterioration or damage due to severe weather conditions such as hail, hurricane, earthquakes, tsunamis, tornadoes, Acts of God or terrorism, discoloration due to exposure to chemicals either directly or in the atmosphere, is not covered by this Limited Warranty.

If service from authorized personnel is necessary to perform any work, you will be responsible for all labor charges outside of labor warranty period.

All replacement parts will carry out the remainder of warranty on the original parts.

To Obtain Warranty

Call 1-866-946-1096

8am - 4:30pm CST

Warranty Restrictions

- This warranty applies only when the water heater is used in the United States and Canada.
- This warranty gives you specific legal rights, and you may also have other rights which vary from state to state.

Manufacturer:

Grand Hall Enterprise Co., Ltd.

9th Fl., No.298, Rueiguang Rd., Neihu,

Taipei, Taiwan (114)